

ATLAS COPCO SIMBA M7C



Features

The Simba M7C is a very mobile electric hydraulic, top hammer production drill rig, capable of drilling in drive sizes larger than 4.5m to 4.5m. By utilising a range of drifters, this rig is capable of drilling the following holes 51mm using R32 speed rods, 64mm using T38 speed rods, 76mm using T45 speed rods, 89mm using ST58 tubes or T51 speed rods. The Rig Control System (RCS) provides efficient and high precision long hole drilling, whilst ensuring an ergonomic working environment and long consumable life.

Specifications

- Weight 17,800 kg
- Width 2,350mm
- Trimming Height 2,875mm
- Feed rail length 4.1m
- Height with roof up 2,965mm
- Trimming length 11,560mm
- Four wheel drive, articulated steering carrier, powered with a low-emission, turbo charged diesel engine
- Additional emergency and park brake
- Max trimming speed on flat ground 15km/h, 1:8 decline 5km/h
- FOPS approved protective roof
- Turning radius, Outer; 6,300mm, Inner; 3,800mm
- Total 1000v electrical requirement 118kW, including two 55kW motors
- Rod Handling system RHS 27, allowing mechanised drilling up to 32m holes
- Ring drilling with parallel holes upwards and downwards up to 5500mm apart
- Capable of dump drilling +30° forward
- Drilling using water or air mist to suppress dust.
- Front and rear hydraulic stingers to ensure stable setup of the feed rail.
- Electronic angle reading system
- 65L AFFF Fire suppression system • 9kg Dry Chemical fire extinguisher
- Laser offsets:

	0°	5°	10°	15°	20°
4.5m	5.0m	5.2m	5.4m	5.7m	5.9m
5.0m	5.0m	5.2m	5.5m	5.8m	6.1m
5.5m	5.0m	5.3m	5.6m	5.9m	6.3m

PERSEVERANCE

DRILLING UNDERGROUND

ATLAS COPCO SIMBA M7C

SWING

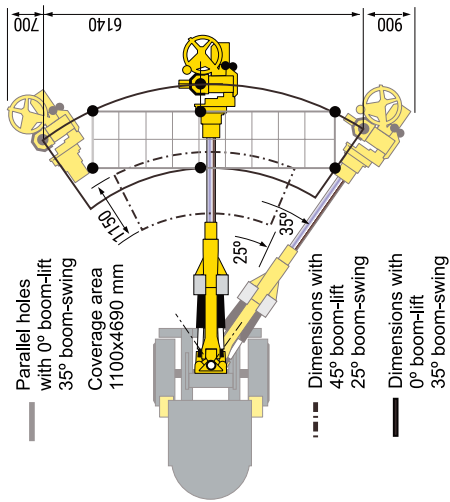

REACH

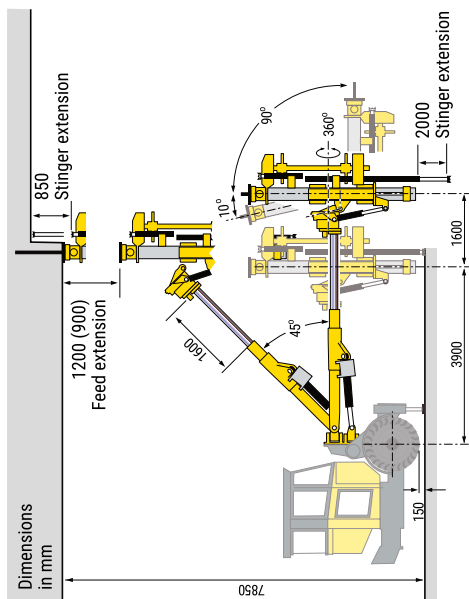

SIDE VIEW

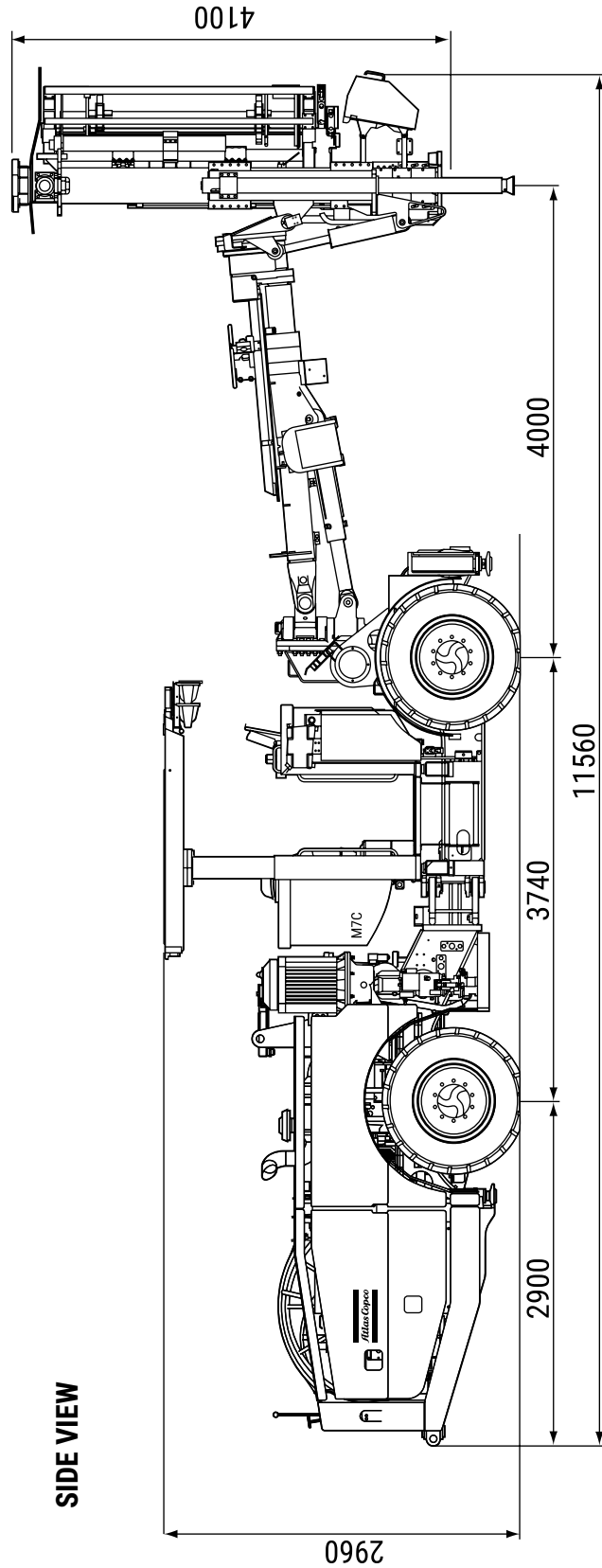

ATLAS COPCO SIMBA M7C

LASER OFFSETS

