

ATLAS COPCO SIMBA M6 C



Features

Production long-hole drilling rig with top hammer drill. The Rig Control System (RCS) provides efficient and high precision long hole drilling, and also ensures an ergonomic working environment and longer consumable life.

Ring drilling with parallel holes upwards/downwards up to 3.0m apart. Hole diameter 51mm to 115mm.

Specifications

- Weight 26,000 kg
- Width 2210mm
- Cabin 3100mm
- Length for transport 10,420mm
- Deutz BF4M 1013C motor, 112kW at 2300 rpm
- Max tramming speed –
flat: 15km/h, incline (1:80): 5km/h
- Carrier, 4 wheel drive, articulated steering (41°)
Automatic differential lock on front axle, limited slip
- Certified FOPS/ROPS approved cabin
- 1000 volt electric hydraulic operation.
Total installed power 138kW (main motors 1x55 + 1x75)
- Low voltage system 24V
- Four mounted stingers for a rock solid set up for drilling
- Atlas Copco Rig Control System (RCS)
- 1838VS and 2550VS drifters using
T38, T45 and T51 running gear
- ST58 to ST68 tubes available
- Rod handling system, RHS27 (27 + 1)
mechanised drilling up to 51m
- Sandvik 65L M-Series fire suppression
with pendulum pivot at 600m
- Hydraulic water booster pump capacity at
15bar 250L/min, min inlet pressure 2bar
- Laser offsets:

	0°	5°	10°	15°	20°
4.5m	3.0m	3.3m	3.6m	4.0m	4.4m
5.0m	3.0m	3.3m	3.7m	4.1m	4.6m
5.5m	3.0m	3.4m	3.8m	4.2m	4.7m

ATLAS COPCO SIMBA M6 C

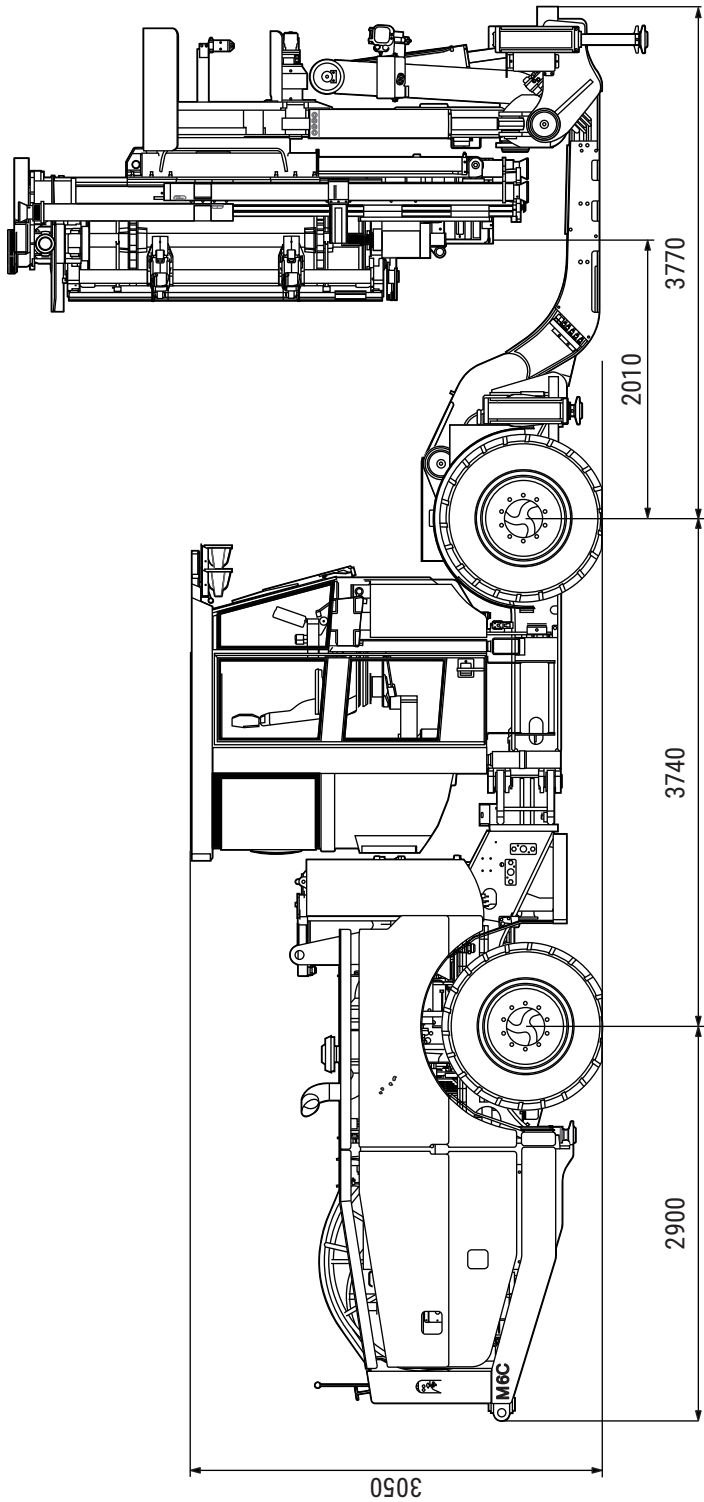

LASER OFFSETS

	0°	5°	10°	15°	20°
4.5m	3.0m	3.3m	3.6m	4.0m	4.4m
5.0m	3.0m	3.3m	3.7m	4.1m	4.6m
5.5m	3.0m	3.4m	3.8m	4.2m	4.7m

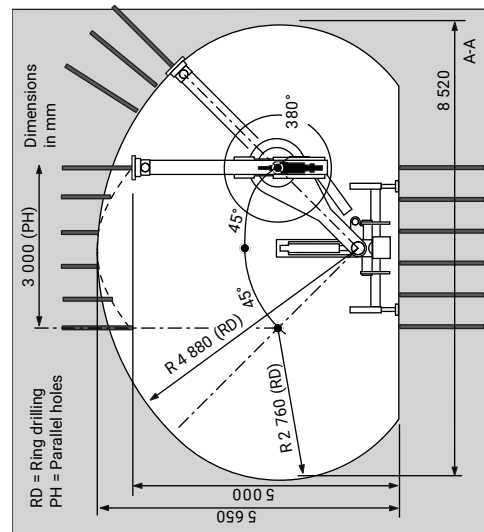
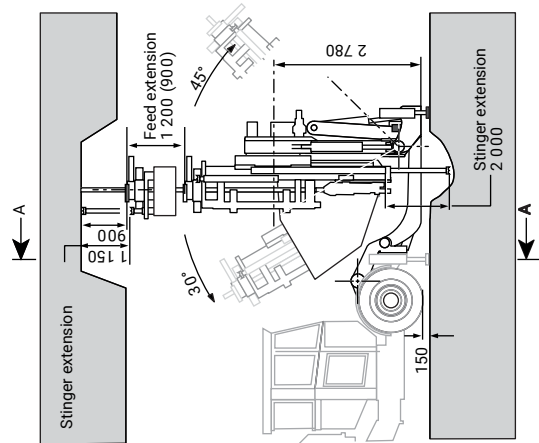

Coverage area.

The technical information and photographs contained in this document are reproduced courtesy of Atlas Copco Australia Pty. Limited